

Lovejoy B-FLEX couplings consist of a set of resilient BARREL shaped bushes with pins & nuts and two flanged hubs of graded cast iron.

These special BARREL shaped bushes permit the MISALIGNMENT IN ALL DIRECTIONS and give extra torsional flexibility as compared to plain bushes. These couplings are suitable for general engineering application requiring reliable power transmission even under conditions of shaft misalignments which are often unavoidable.



FEATURES

SIMPLICITY OF CONSTRUCTION

Easy to assemble & disassemble. Suitable for independent running of the drive.

VARYING STIFFNESS CHARACTERISTICS

Special barrel shaped bushes provide progressively increasing stiffness characteristics, hence ensure effective shocks & vibration absorption.

NO LUBRICATION

B-FLEX couplings never require lubrication of any kind.

SIMPLE / EASY MAINTENANCE

No complicated mechanism to demand adjustment or maintenance. Inspection and replacement of bushes is easy and bushes can be quickly fitted without dismantling or moving either of coupled shafts.

LOW OPERATIONAL COST

Only wearing part is low cost bushes which make coupling economical in long run.

SMOOTH & QUIET OPERATION

Reduces vibration & noise arising from severe torque fluctuations.

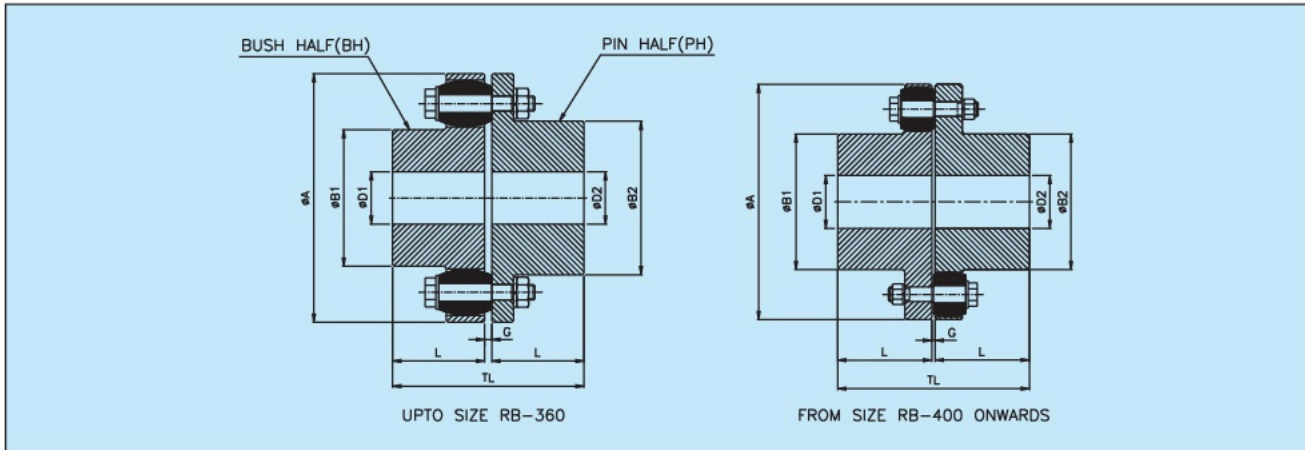

TECHNICAL DATA

Coupling Size	Coupling Rating @100RPM						Max. Speed rpm	Min. Bore	Max. Bore		ϕA	$\phi B1$	$\phi B2$	G	L	TL	Wt. in kg.	M.I.(WR ²) in ² kgm	Max. Misalignment		
	Synthetic Rubber		Polyurethane		HTrans				$\phi D1$	$\phi D2$									Axial (mm)	Radial (mm)	Angular
	KW at 100 RPM	Torque Nm	KW at 100 RPM	Torque Nm	KW at 100 RPM	Torque Nm															
RB-105-3	1.0	95	1.5	143	2.5	239	7200	11	30	32	105	48	50	2-6	45	94	2	0.0030	2	0.3	1°
RB-116-4	1.5	143	2.3	215	3.8	358	6100	12	39	42	116	60	68	2-6	45	94	2.6	0.0050	2	0.3	1°
RB-125-4	1.7	162	2.6	244	4.3	406	5500	14	45	50	125	68	78	2-6	50	104	3.1	0.0070	2	0.4	1°
RB-144-6	3.3	315	5.0	473	8.3	788	4900	18	50	60	144	82	91	2-6	55	114	4.3	0.012	2	0.4	1°
RB-162-6	5.5	525	8.3	788	14	1313	4500	22	60	65	162	89	100	2-6	60	124	7.5	0.030	2	0.4	1°
RB-178-6	6.7	640	10	960	17	1600	3800	24	70	75	178	105	115	2-6	70	144	10	0.040	2	0.5	1°
RB-198-10	13	1241	20	1862	33	3104	3400	28	80	90	198	124	135	2-6	80	164	13	0.062	2	0.5	1°
RB-228-11	21	2005	32	3008	53	5013	3000	28	90	100	228	133	146	4-10	90	187	18	0.100	3	0.6	1°
RB-252-12	32	3056	48	4584	80	7639	2700	38	105	115	252	156	167	4-10	100	207	24	0.17	3	0.6	1°
RB-285-11	48	4584	72	6875	120	11459	2400	48	115	125	285	170	186	4-10	110	227	35	0.31	3	0.7	1°
RB-320-12	64	6112	96	9167	160	15279	2100	55	125	135	320	196	212	4-10	125	257	51	0.53	3	0.7	1°
RB-360-11	93	8881	140	13321	233	22202	1900	65	135	150	360	212	232	4-12	140	288	73	1.02	4	0.9	1°
RB400-10	126	12032	189	18048	315	30080	1700	75	160		410	230		4-12	160	328	101	1.70	4	1.1	1°
RB-450-12	195	18621	293	27932	488	46553	1500	85	180		450	260		4-12	180	368	137	2.90	4	1.1	0.5°
RB-500-14	270	25783	405	38675	675	64458	1350	95	200		500	290		4-12	200	408	180	4.70	4	1.1	0.4°
RB-560-10	325	31035	488	46553	813	77588	1200	95	225		560	320		4-8	220	446	278	10.70	2	1.5	0.3°
RB-630-12	440	42017	660	63025	1100	105042	1050	100	250		630	355		4-8	240	486	365	17.4	2	1.5	0.3°
RB-710-12	785	74962	1178	112443	1963	187405	950	100	260		710	385		5-9	260	527	516	33	2	1.8	0.3°
RB-800-14	1047	99981	1571	149972	2618	249953	850	100	280		800	420		5-9	290	587	691	53	2	1.8	0.3°
RB-900-16	1623	154985	2435	232478	4058	387463	750	100	305		900	465		5-9	320	647	927	86	2	1.8	0.3°
RB-1000-18	2042	194997	3063	292495	5105	487492	680	125	320		1000	515		5-10	350	708	1224	142.8	2	2.0	0.1°

- PH = Pin Half (Drive) upto size 360
- BH = Bush Half (Driven) upto size 360

SPARE PARTS

Coupling SIZE	Pin Half Part No.	Bush Half Part No.	Pin + Washer Part No.	Bush Part No.	No. Of Pin-Bush Assy./Coupling	Nut Size
RB-105-3	RB-105-3/1	RB-105-3/2	RB/P-2	RB/B-2	3	M8
RB-116-4	RB-116-4/1	RB-116-4/2	RB/P-2	RB/B-2	4	M8
RB-125-4	RB-125-4/1	RB-125-4/2	RB/P-2	RB/B-2	4	M8
RB-144-6	RB-144-6/1	RB-144-6/2	RB/P-2	RB/B-2	6	M8
RB-162-6	RB-162-6/1	RB-162-6/2	RB/P-3	RB/B-3	6	M10
RB-178-6	RB-178-6/1	RB-178-6/2	RB/P-3	RB/B-3	6	M10
RB-198-10	RB-198-10/1	RB-198-10/2	RB/P-3	RB/B-3	10	M10
RB-228-11	RB-228-11/1	RB-228-11/2	RB/P-4	RB/B-4	11	M14
RB-252-12	RB-252-12/1	RB-252-12/2	RB/P-4	RB/B-4	12	M14
RB-285-11	RB-285-11/1	RB-285-11/2	RB/P-5	RB/B-5	11	M16
RB-320-12	RB-320-12/1	RB-320-12/2	RB/P-5	RB/B-5	12	M16
RB-360-11	RB-360-11/1	RB-360-11/2	RB/P-6	RB/B-6	11	M20
RB-400-10		RB-400-10	RB/P-7	RB/B-7	10	M20
RB-450-12		RB-450-12	RB/P-7	RB/B-7	12	M20
RB-500-14		RB-500-14	RB/P-7	RB/B-7	14	M20
RB-560-10		RB-560-10	RB/P-8	RB/B-8	10	M36
RB-630-12		RB-630-12	RB/P-8	RB/B-8	12	M36
RB-710-12		RB-710-12	RB/P-9	RB/B-9	12	M42
RB-800-14		RB-800-14	RB/P-9	RB/B-9	14	M42
RB-900-16		RB-900-16	RB/P-9	RB/B-9	16	M42

NOTES - * All dimensions are in mm. Unless otherwise specified.

* Weight & inertia figures are at maximum bores.

* Each coupling is capable of withstanding maximum torque of 3 times of nominal torque for short durations such as during start up.

* For vertical installation contact RATHI.

- In view of our constant endeavour to improve quality of our products, we reserve the right to alter or change Specifications without prior notice.
- This document is the intellectual property of rathi transpower pvt. Ltd. And subject to copyright.