

Min ●●●●● Max

Shift chain® ST 055E Enclosed Type

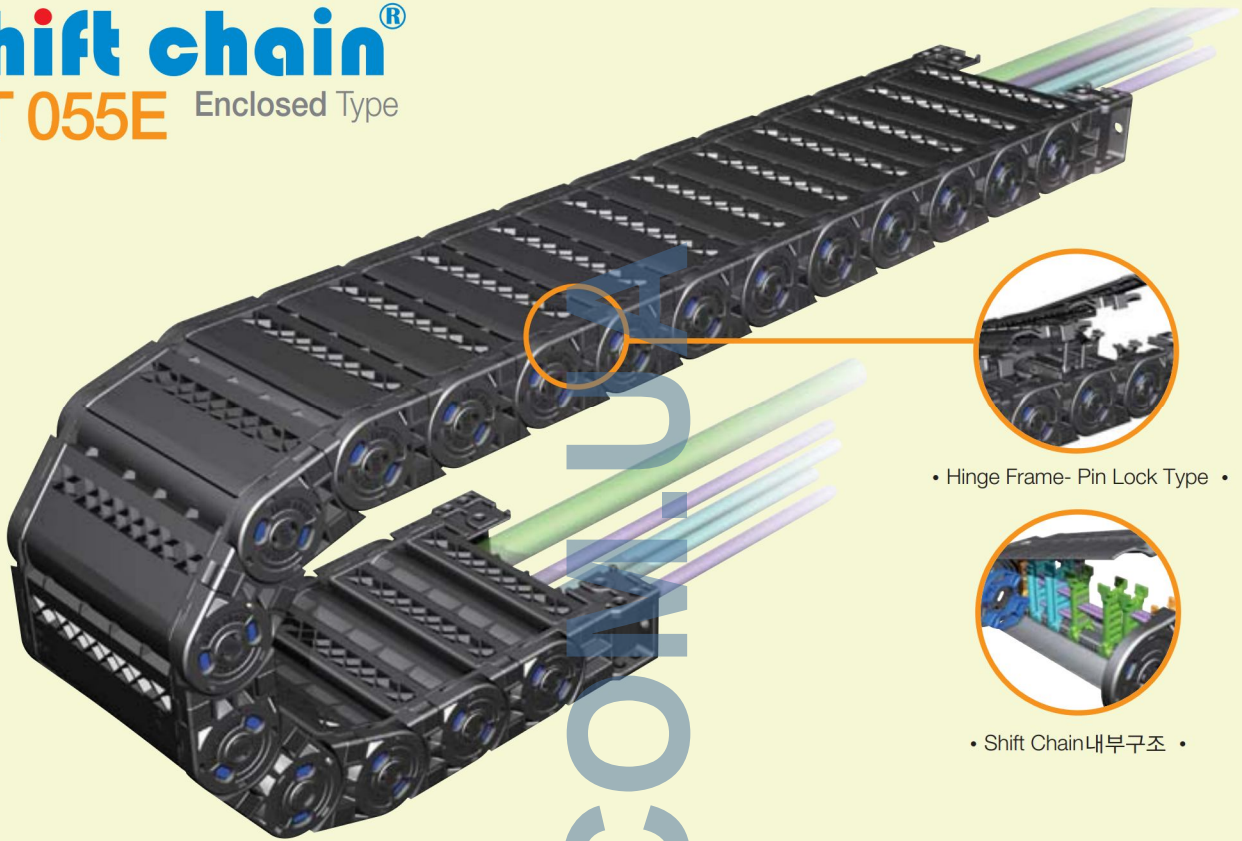

• Hinge Frame- Pin Lock Type •



• Shift Chain내부구조 •

SHIFT-CHAIN

SAEN-CHAIN

REVOLVING-CHAIN

HELIX-CHAIN

MATERIAL

- **Chain material:**
CPS-polyamide with glass fiber reinforced UL94-HB
- **Low Noise & Low Mote**
- **Speed :** 10m / sec
- **Temperature :** -30°C ~ +130°C
- **Other installation Length**
Vertical curve above= max 2.0m
Vertical curve below= max 40m
Side Mounted, Unsupported= max 1.0m

Applications

Shift Chain E-Type can be found on car manufacturer's welding line, robot carriages and press lines and on any machine where excess material can damage your inserted cables.

산업현장, 외부위험 요소로부터 케이블의 보호가 필요한 용접라인, 도장라인 등에 적용. 건츄리로봇, 공작기계, 용접기계, 로봇캐리지 등의 외부위험 요소로부터 케이블의 보호가 요구되는 케이블 체인의 적용 사업장에 사용가능.

Calculation of the chain length

$$\left[L = \frac{Ls}{2} + Lp \right]$$

Load diagrams self-supporting length

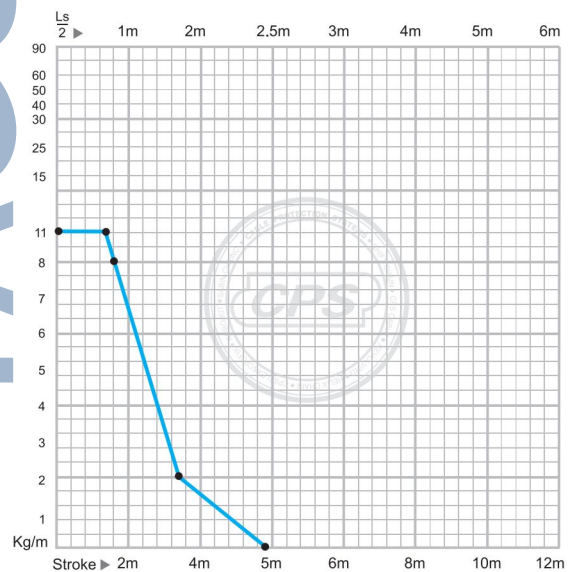

ROBOT-KIT

OP-STEELX

OP-SERX

ST 055E Enclosed Type

LAYOUT OF THE CHAIN

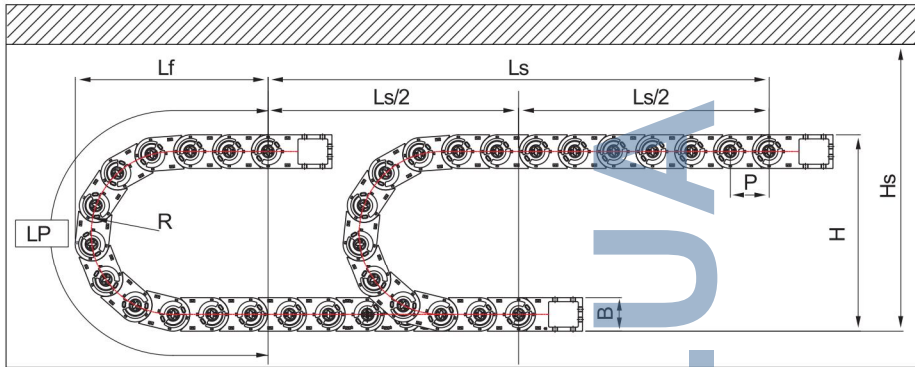

- Ls:** Stroke
- Lp:** Loop Length
- Lf:** Loop Projection
- Hs:** Safe Space

(Dimensions in mm)

Bending radius R	-	-	100	125	150	200
Lp	-	-	535	613	692	849
Lf	-	-	236	261	286	336
H	-	-	252	302	352	452

ST 055E Type

- Pitch P:** 55mm
- Height B:** 52mm
- Height H:** 2R+52mm
- Hs** ≥ H+35mm

ORDERING (주문방법)

ST 055E. 150. R150 / F - 1800L : 10ST



- 주문수량 Q' ty(set)
- 체인길이 Length(mm)
- 브라켓 Free End Bracket
- 곡률반경 Bending Radius
- 내폭 Inside Width
- 밀폐형태입 Enclose Type

Shift Chain

BRACKET TYPE (브라켓타입)

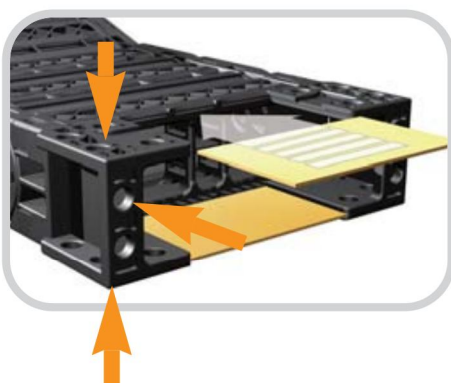

FEB (Free End Bracket)

FEB Fixes the cable chain to the machinery or moving application. CPS has improved mounting efficiency by unifying the existing Easy End Bracket and Normal End Bracket.

체인을 고정하는 끝부분으로 기존 Easy End Bracket 과 Normal End Bracket 을 하나로 통합한 방식으로 취부의 효율성을 높임.

▶ Above products are patent registered item which can be protected by industrial property right. (상기제품은 특허등록 제품으로 산업재산권의 보호를 받는 제품입니다.)

ST 055E Enclosed Type

SHIFT CHAIN

SAEN CHAIN

REVOLVING CHAIN

HELIX CHAIN

ROBOT KIT

OPSHLEX

OPSHK

CHAIN CROSS SECTION



Chain Type	A	B	C	D	Bending Radius(R)	Weight in kg/m
ST 055E.050	71		50			1.36
ST 055E.075	96		75			1.56
ST 055E.100	121	52	100	38.5	100, 125, 150, 200	1.76
ST 055E.125	146		125			1.97
ST 055E.150	171		150			2.21

FREE END BRACKET

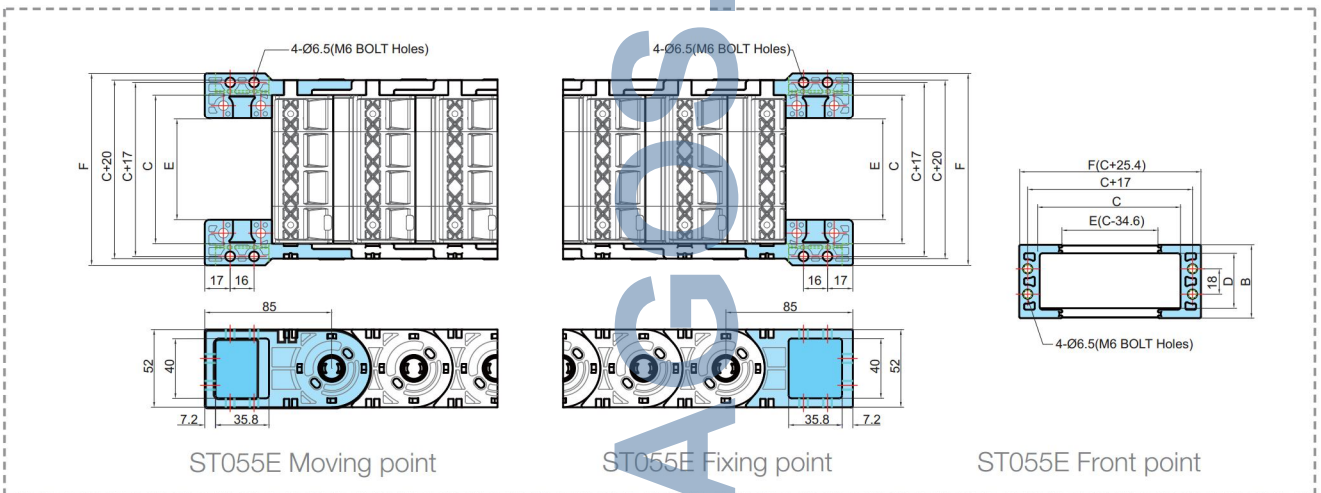

Chain Type	F	B	C	D	E	Hole Type
ST 055E.050	79		50		18	M6 Bolt Holes
ST 055E.075	104		75		43	
ST 055E.100	129	52	100	38.5	68	
ST 055E.125	154		125		93	
ST 055E.150	179		150		118	

ST 055E Enclosed Type

DIVIDERS & SEPARATORS

Dividers (Vertical) and Separators (Horizontal) divide the inner chamber of the cable chain to give each cable diameter its own center and keep the cables separated from each other. The use of separator in some cases, can also reduce the width requirements as two or more levels can be made within the same chamber. To prevent twisting or damage to the cables, as a rule, there needs to be at least 10% space between the inserted cable and its enclosure.

디바이더(세로분리대)와 세퍼레이터(가로분리대)는 체인내에 많은 케이블들이 입선될 시 케이블들을 서로 분리하여 케이블상호간의 마찰로 인한 **피복손상 및 단선**을 방지하는 역할을 하며 케이블과 10%이상의 여유공간을 확보해야 합니다.

또한 케이블을 체인내 2단이상 입선시 반드시 세퍼레이터를 디바이더에 결합하여 사용하여 케이블의 꼬임방지와 피복손상을 방지할 수 있습니다.

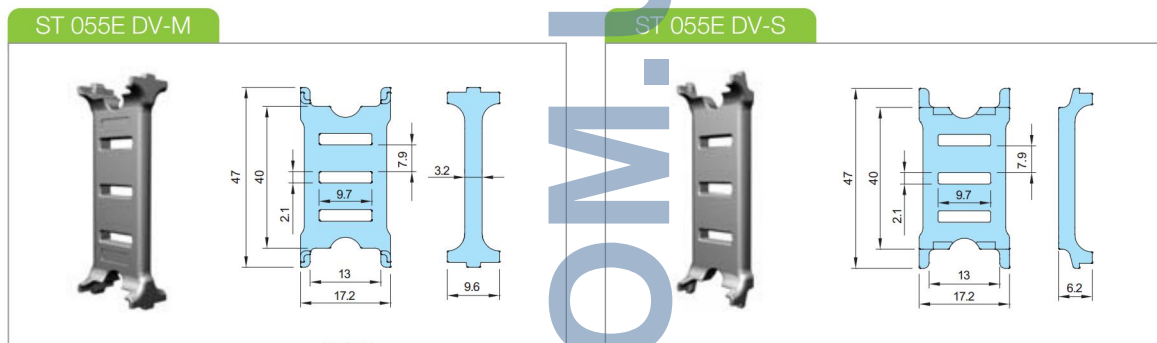

▶ Assemble divider every Two links. / 2링크마다 결합.

ST 055E Separators (SP) (No. : S-SP/M)

Chain Type	Separators	SP035	SP050	SP055	SP075	SP100	SP125	SP150	SP175	SP200
ST 044E		○	○	○	○	○	○	○	○	○
ST 055E		○	○	○	○	○	○	○	○	○

TIE WRAP



Attach to Bracket (브라켓 결합용)

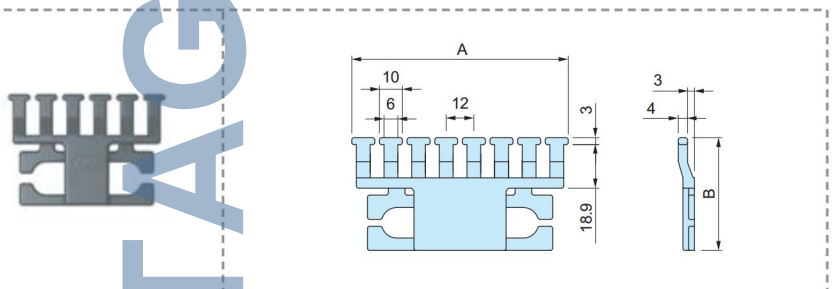

The Tie Wrap separated from the Shift Chain bracket, when installed properly, protects the inserted cables from becoming entangled and twisted during operation.

There are two types in the tie wrap; Attached & Unattached to the bracket.

Tie Wrap은 Shift Chain의 브라켓을 기준으로 설치함으로써 체인의 움직임으로 인해 체인내의 케이블이나 호스가 당겨져 **단선되는 경우를 방지**할 수 있다. Shift Chain의 Tiewrap은 브라켓부분과 근접해서 사용할 수 있는 사양과 브라켓에 결합해서 사용할 수 있는 사양으로 구분되어 사용할 수 있다.

When using the tie wrap option for the Shift Chain ST 055 series, the corresponding frame sizes will be 50, 75, 100, 125, 150, 175 and 200mm respectively.

ST 055 제품은, 삽입형 Tiewrap을 사용하며 적용되는 Frame은 50, 75, 100, 125, 150, 175, 200 입니다.