

LC 40 - 1

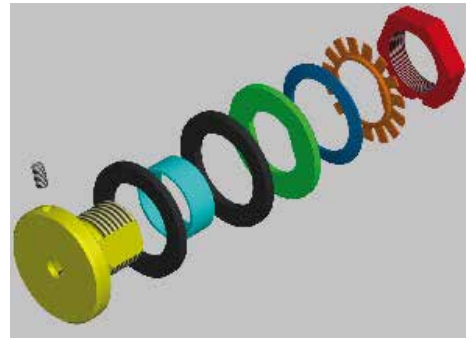

LC 85 - 2

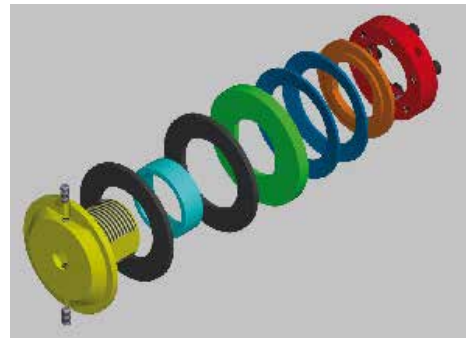

LC 95 - 1

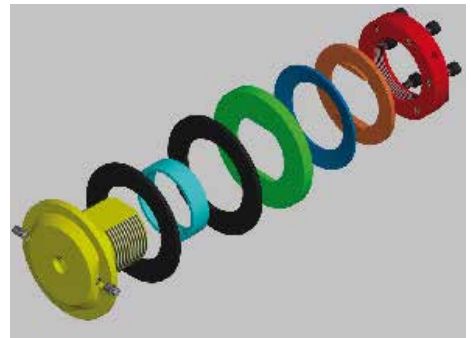

LC 170 - 2

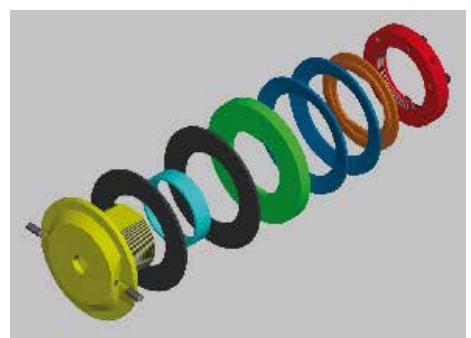



The torque limiter finds employment where an overloaded protection on mechanic transmission components is necessary (kinematics and machines).

The employment system easy and efficient, offers full operative reliability when the required torque exceeds the preloaded value and automatically restores the transmission when the overloaded ceases.

The transmission mechanical component, between pulleys, chain wheels and gears is within clutch that elements that tighten through the compression of the Bauer springs develops a friction force defined by the clamping of the sleeve.

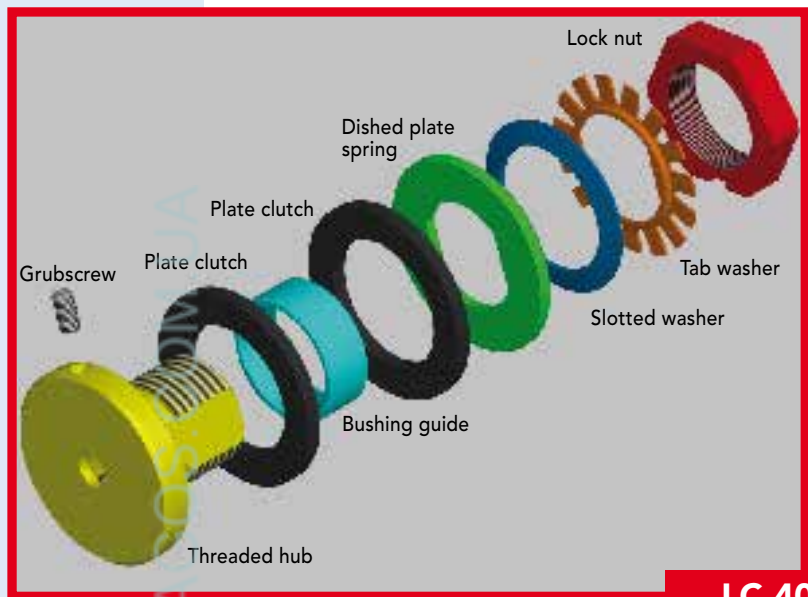
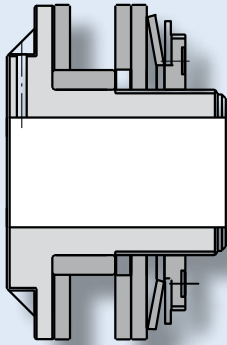

LC 40-50

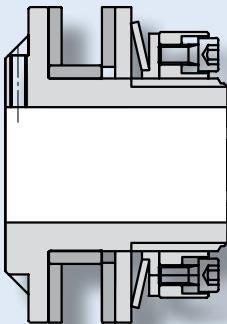

LC 65-85-95-120-140-170



CHOICE OF THE TORQUE LIMITER:

T_{kw} = Power in kW

n = revolutions per minut

M_t = torque (Nm)

The torque is given by the relation:

$$M_t = \frac{9550 \cdot T_{kw}}{n}$$

Example:

To use an electrical motor with the following features:

Power 4 kW e $n = 1.550$ g/1'

$$M_t = \frac{9550 \cdot 4}{1550} = 24.64 \text{ Nm}$$

So we will choose a limiter with a torque equal to or higher than 24,64 Nm

**LC****1 spring**

TORQUE
100% Nm

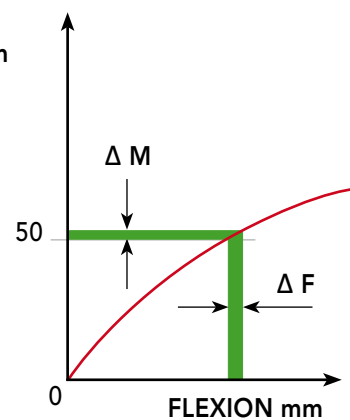
**LC****2 springs**

TORQUE
100% Nm

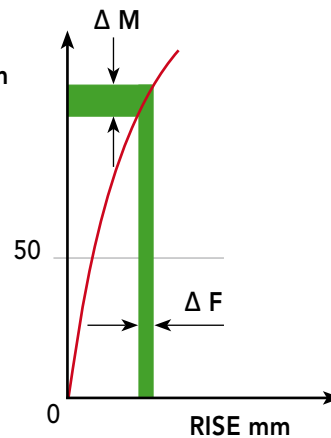

Scheme of the Belleville springs DIN 2093



DIMENSIONS AND SETTINGS

EXAMPLE:

LC 85-1 with 1 spring

LC 85-2 with 2 springs

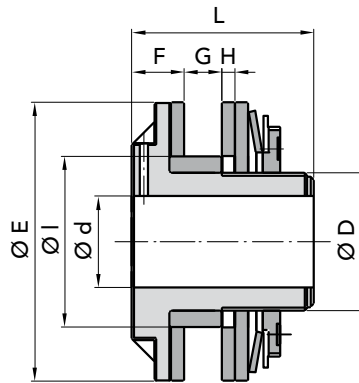

LC 40-50

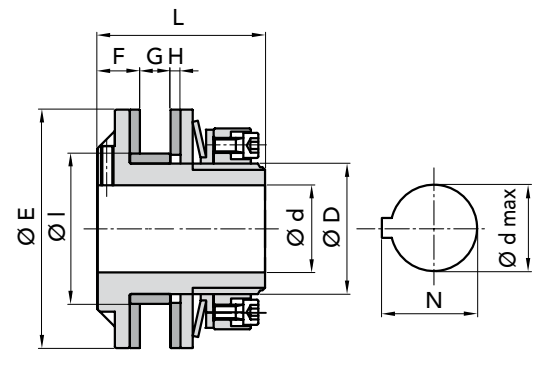

LC 65-85-95-120-140-170

TYPE	Limiter part number	Dished plate spring part number	Disk Friction part number	Part number bushing	ØE	ØI	Ød	F	G	H	ØD	L	max. bore keyway DIN 6885/1 on request		Max torque N/m	N° of springs	sprockets for chain (u) = 1,6 : 2		Weight Kg.
													Ød max	N			Ø pitch for roller	N° teeth	
LC 40-1	8040001	8040050	8040020	8040030	40	26	7	9	6	3	22	30	14	16,3	15	1	3/8" x 6,65	18-21	0,190
LC 40-2	8040002																1/2" x 8,51	15	0,195
LC 50-1	8050001	8050050	8050020	8050030	50	35	7	10	6	3	32	35,5	20	22,8	30	1	3/8" x 6,65	19-23	0,365
LC 50-2	8050002																1/2" x 8,51	17	0,370
LC 65-1	8065001	8065050	8065020	8065030	65	45	10	16	9	4	36	53	22	24,8	70	1	3/8" x 6,65	27	0,750
LC 65-2	8065002																1/2" x 8,51	21	0,800
												55					5/8" x 10,16	19	
LC 85-1	8085001	8085050	8085020	8085030	85	52	15	16	11	4	45	59	25	28,3	130	1	3/8" x 6,65	38	1,470
LC 85-2	8085002																1/2" x 8,51	25	1,480
												61					3/4" x 12,07	18	
LC 95-1	8095001	8095050	8095020	8095030	95	60	15	17	11	4	52	67	35	38,3	190	1	1/2" x 8,51	30	2,160
LC 95-2	8095002																5/8" x 10,16	25	2,170
												52					3/4" x 12,07	19	
LC 120-1	8120001	8120050	8120020	8120030	120	73	20	19	16	4	64	78	45	48,8	350	1	1/2" x 8,51	38	4,000
LC 120-2	8120002																5/8" x 10,16	32	4,100
												52					3/4" x 12,07	25	
												64					1" x 15,88	21	
LC 140-1	8140001	8140050	8140020	8140030	140	90	20	22	17	4	85	86,5	60	64,4	650	1	3/4" x 12,07	35	5,900
LC 140-2	8140002																1" x 15,88	21	6,000
LC 170-1	8170001	8170050	8170020	8170030	170	100	28	25,5	18,5	4,5	90	94	65	69,4	1000	1	3/4" x 12,07	35	9,200
LC 170-2	8170002																1" x 15,88	25	9,400
												94					1"1/4 x 19,05	22	

Pay attention. You are strongly advised to use the torque limiters of the series LC Cleaning, checking carefully that products or oily liquids in general do not reach in any way the friction materials in order to not cause a sudden and inevitable performance degradation. Adjust the guide bush according to their needs. The clutch plates are constituted by a structure that is absolutely free of asbestos.



CAD drawings available on our site
www.chiaravalli.com

Quantity, availability and prices
 on B2B Chiaravalli